

# ANACONDA<sup>®</sup>

CRUSH | SCREEN | STACK

## J960 'ECO' JAW CRUSHER



**THE ANACONDA RANGE OF MOBILE CRUSHERS HAS BEEN DESIGNED WITH REAL FOCUS ON COST SAVINGS AND PERFORMANCE.**

The J960 'ECO' represents the future of crusher design with a wide range of features to make it one of the most economical crushers in the world. The robust design will produce a constant rate of crushed product at up to 150 tph and will do so without much fuss!

The J960 'ECO' Jaw Crusher is a dual power model with extremely low fuel consumption and boasts arguably the quietest operating readings in the world. Ideal for 'urban' crushing, the J960 has been designed to transport easily from site to site, measuring 2.5m wide and weighing in at 26 tons.

### FEATURES & BENEFITS

- DUAL POWER AS STANDARD
- AUXILIARY POWER SUPPLY SOCKET
- LOW FUEL CONSUMPTION
- LOW MOTOR NOISE
- FORWARD & REVERSE JAW DRIVE
- 40 - 150MM JAW SETTING
- HIGH CLEARANCE BETWEEN JAW & BELT
- OVERBAND MAGNET
- DUST SUPPRESSION ON MAIN CONVEYOR
- 26 TONNE – 2.5 METERS WIDE

### OPTIONS

- ENGINE TYPE
- DIRT CONVEYOR
- FEED HOPPER EXTENSION
- EXTENDED MAIN CONVEYOR
- DUST CANOPY OVER DISCHARGE BELT
- BELT WEIGH
- LIGHTS

### WEIGHT

57,320 LBS / 26000 KG



# ANACONDA®

CRUSH | SCREEN | STACK

## J960 'ECO' JAW CRUSHER

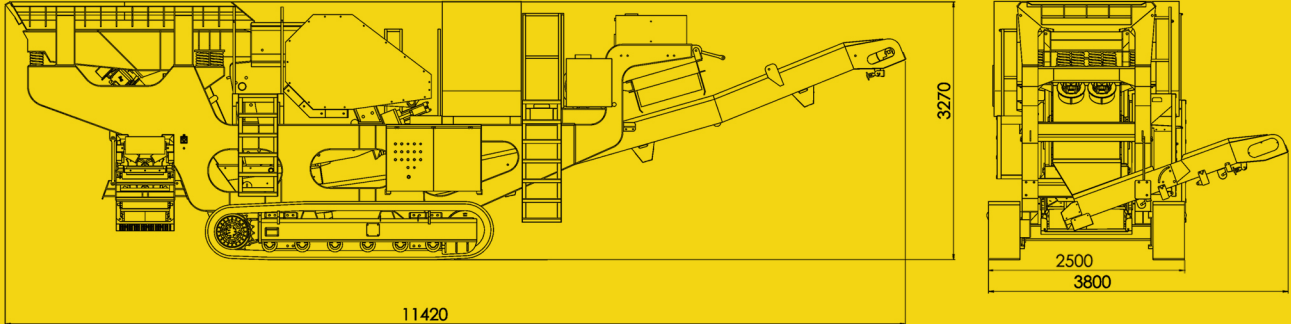

### WORKING DIMENSIONS

- DISCHARGE HEIGHT 2800MM
- GROUND CLEARANCE 245MM
- FEED HEIGHT 3270MM

### TRANSPORT DIMENSIONS

- 2500MM (W) X 3270MM (H) X 11425MM (L)

### JAW CRUSHER BOX

- SIZE 900X600
- MAXIMUM FEED SIZE 500MM
- MAXIMUM JAW SETTING 120MM
- MINIMUM JAW SETTING 40MM
- HOURLY CAPACITIES 40-150 TONNES PER HOUR (DEPENDENT ON MATERIAL TYPE & CSS)
- RPM300
- MANUAL HYDRAULIC JAW ADJUSTMENT
- REVERSE JAW DIRECTION
- SINGLE TOGGLE
- HEAVY STEEL FABRICATED BODY
- OPTIMUM DESIGN INVERTIBLE MANGANESE JAW PLATES

### POWER UNIT

- FOGO FI100 (100KVA)
- IVECO ENGINE 87KW
- FUEL CAPACITY 210 LITRES
- 2 SOCKET TERMINAL BOARD (400V/16A & 230V 16A)

### CONTROL CABINET

- SIEMENS CONTROLS
- SIEMENS INVERTER
- REMOTE CONTROL
- EXTERNAL POWER SOCKET FOR MAIN USE

### MAIN CONVEYOR

- BELT WIDTH 800MM
- DISCHARGE HEIGHT 2800MM
- 320M MOTORIZED PULLEY

### DIRT BELT

- BELT WIDTH 450MM
- DISCHARGE HEIGHT 1600MM
- 220M MOTORIZED PULLEY

### MAGNET

- TYPE PERMANENT
- FIELD INTENSITY 570 GAUSS/200MM
- CLEARING BELT WIDTH 750MM

### FEED HOPPER

- NOMINAL VOLUME 3M<sup>3</sup>
- SIDE FEED LENGTH 3000MM
- WIDTH 1575MM

### FEEDER GRIZZLY

- LENGTH 2900MM
- WIDTH 900MM
- LENGTH OF GRID 800MM
- STANDARD APERTURE 50MM
- ADJUSTABLE SPEED
- REMOTE STOP-START

**ANACONDA®**  
CRUSH | SCREEN | STACK



**Head Office**  
Anaconda Equipment International,  
Ardboe Business Park, Kilmascally Road  
Dungannon, Co. Tyrone, BT71 5BJ

Tel: +44 (0) 28 867 37878  
Email: [sales@anacondaequipment.com](mailto:sales@anacondaequipment.com)  
Web: [www.anacondaequipment.com](http://www.anacondaequipment.com)

DEALER STAMP HERE

CURRENT MODELS MAY DIFFER FROM THOSE FEATURED IN THIS BROCHURE.  
ANACONDA RESERVES THE RIGHT TO MAKE CHANGES TO THE PRODUCT  
DESIGN WITHOUT RESERVATION AND WITHOUT NOTIFICATION